

Elite Engineering Catch Can Install

2010 Camaro (L99 and Magnuson Supercharged Engines)



Tools Needed:

- Flat Head Screwdriver
- 6mm Allen Wrench
- Razor Knife
- Pliers/Vise Grips
- 1/8" Allen Wrench
- 15mm Socket or Wrench

Installation Instructions:

1. Disconnect negative side of battery to avoid any potential electrical problems.
2. Locate belt/pulley tension bolt on passenger's side of engine.

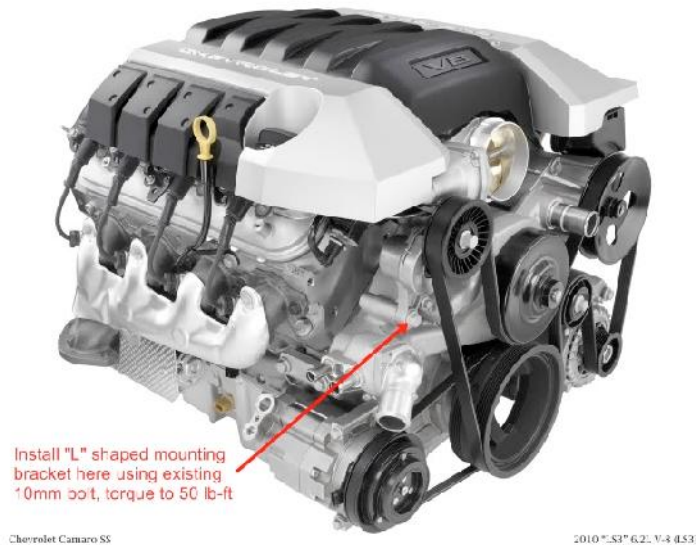

Figure 1: Location "L" Mounting Bracket

3. Using a 15mm socket, carefully loosen and remove this threaded bolt.



www.eliteengineeringusa.com

Elite Engineering



High Quality Performance Parts

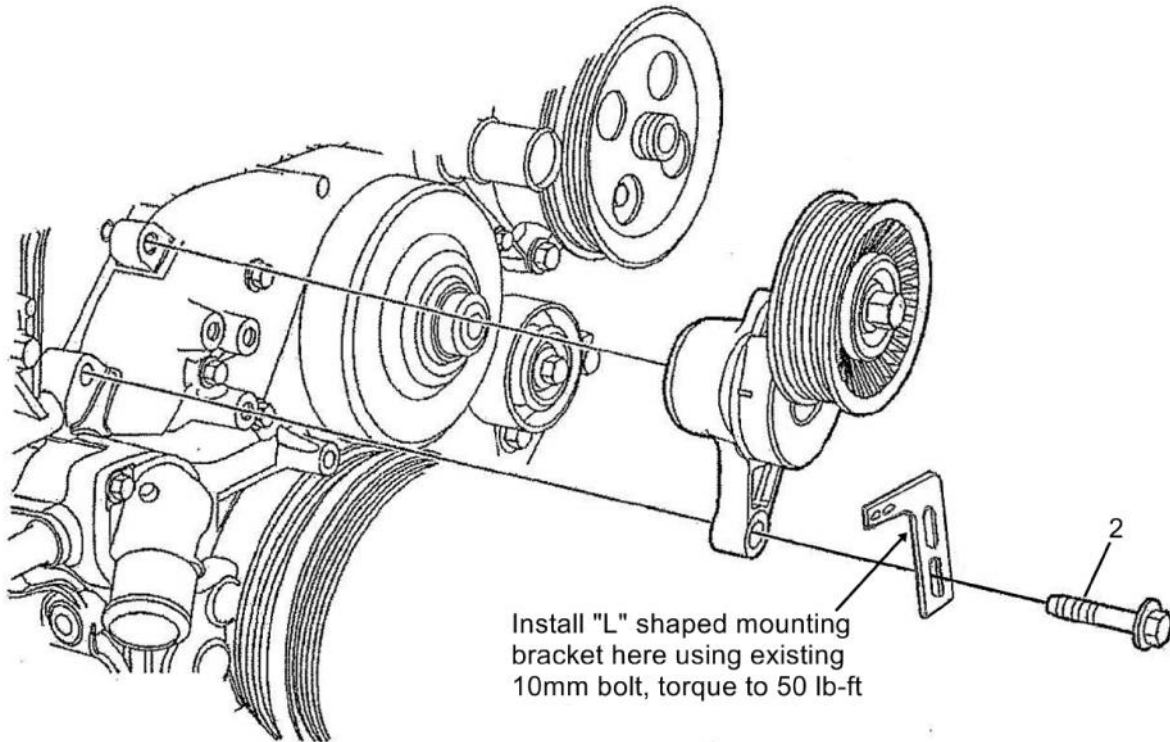

Figure 3: Belt Drive Tensioner, engine: 4.8L, 5.3L, 6.0L, 6.2L, or 7.0L

- 4 Insert and Install the provided "L" shaped bracket as shown above
- 5 Hose Barbs should be threaded installed into Catch Can at this time. Point the barb fittings in the orientation as shown in Figure 7. Once the "L" bracket is installed, you cannot rotate the Exit (side) hose barb.
- 6 Secure catch can onto mounting bracket using (2) M10 machine screw and 6mm Allen wrench. Try to get assembly as level as possible. Adjustments can be made once catch can is installed.
- 7 Locate existing PCV line running from the driver's side rear of the engine, down and over the intake plenum, and into a connection in the plenum to the left of the throttle body. It helps to first unclip EVAP lines by squeezing white tabs. Figures 4 & 5 show connections.

Figure 4: PCV Line Intake Plenum Connection



Figure 5:





8 Install included rubber hose and two (2) included hose clamps onto PCV outlet and inlet as seen in pictures below:
Rubber Hose Installed on PCV Inlet (To Side of Catch Can)



- 9 Install and tighten 90° NPT elbows onto catch can. Both elbows should be pointed to face engine once catch can is installed. Install catch can onto bracket using two (2) included 1/8" machine screws and 1/8" Allen wrench.

Figure 7: Catch Can Installed on Bracket



- 10 Route rubber hoses to catch can inlet and outlet and cut to fit with razor knife. Secure with two (2) included hose clamps. Connection at rear of engine is routed to the top of the catch can, while the intake plenum connection is routed to side of catch can. Figure 8 shows hose routing.

Figure 8: Hose Routing from PCV Outlet (Line Highlighted in Red for Clarity)



1 Check that catch can is level and that hoses are securely attached. Re-connect negative terminal on battery, start car, and check for leaks at catch can attachment points. Catch can bottom and mesh filter should be removed, emptied, and cleaned at each oil change.

2 Enjoy the advantages of no oil in the intake from now on!

Note on Magnuson TVS 2300 Installation:

All steps are the same, except for the PCV inlet connection installation. Inlet is located on supercharger body on the right side of the unit. It is the right most brass connection in a group of three connections. It is shown in Figure 10 and is routed to the side of the catch can (unit outlet).

Figure 10: Supercharger Inlet Connection (Routes to Outlet on Catch Can)



For installation questions contact sales@EliteEngineeringUSA.com